



Denver, CO - USA

More Fittings. Higher Quality. Superior Service.

ISO 9001:2015



INTERNATIONAL THREAD CHART

IDENTIFICATION GUIDE



TABLE OF CONTENTS

- Abbreviations
- Introduction
- International Connections
 - British Standard Pipe
 - British Standard Pipe Parallel (BSPP)
 - British Standard Pipe Tapered (BSPT))
 - Flat Face Port with British Standard Pipe Parallel Threads (ISO 1179-1)
 - Flat Face Port with Metric Threads (ISO 9974-1)
 - ISO 6149 Metric Port and Stud Ends
 - Metric 600° Cone
 - Metric compression tube fitting (DIN 2353 240 Cone)
 - Japanese Industrial Standard JIS 300 Flare
 - Komatsu 30j Flare (JIS Metric)

ABBREVIATIONS

NPTF	National Pipe Tapered Fuel
NPSM	National Pipe Straight Mechanical
ISO	International Standards Organization
SAE	Society of Automotive Engineers
JIC	Joint Industrial Council
NFPA	National Fluid Power Association
BSP	British Standard Pipe
DIN	Deutsche Industrial Norme
JIS	Japanese Industrial Standard
BSPT	British Standard Pipe Tapered
BSPP	British Standard Pipe Parallel

FLUID PORT AND CONNECTOR IDENTIFICATION

Because of their varied use in fluid piping systems, ports and connectors need to be correctly identified when adding or replacing hoses or tubes in your specific system.

A thread standard identifies the form, angle, diameter and pitch. ASME B1 .1 and ISO 261 are examples commonly used by thread manufacturers. The American Society of Manufacturing Engineers, American National Standards Institute, International Organization for Standardization, SAE International, British Association, and Deutsches Institut für Normung are a few of the organizations responsible for developing these standards.

FLUID PORT AND CONNECTOR IDENTIFICATION TOOLS:

Calipers:

Used to measure inner and outer thread diameters.

Thread Pitch Gauge:

Used to measure the number of threads per inch, as well as thread to thread spacing in the case of metric connections.

Before you begin measuring, be sure the threads are in good condition. Distorted or worn out threads can give you inaccurate measurements. Once you determine that the threads are in good condition, measure and note the diameter. (An I.D./O.D. caliper is a suitable tool for this.) Match the dimensions provided in this guide with your recorded measurements. You should be aware that due to manufacturing tolerances, your measurements may not specifically match those included in this guide.

You'll need to determine the spacing of the threads, per square inch (or thread to thread distances for metric connections), after measuring the diameter. It is important to be sure the thread pitch gauge properly fits on the threads to get the best accuracy. Note and compare your measurements with those in this guide.

For accurate measurement of four-bolt flanges, use a caliper to measure the port hole diameter of the bolt, and note that number. Then, measure the distance from center to center of the bolt holes, and note the longest spacing.

Dash Numbers:

The sizes of tubes and fluid pipes generally use an abbreviation called a dash number. When describing a fluid pipe or a tube using dash numbers, only the top number of the fraction is used. The bottom number is always 16 and is generally ignored. (Also, be aware that dash numbers are nominal.) **e.g. -8 size is equal to 8/16", or 1/2"**

* Because metric measurements are actual sizes of a tube or a fluid pipe, dash numbers do not apply. For example, an M10x0.5 has threads on the outside of 10 mm with thread spacing of 0.5 mm.

INTERNATIONAL CONNECTIONS

BRITISH STANDARD PIPE

British Standard Pipe connections come in two different types: British Standard Pipe Parallel (BSPP); and British Standard Pipe Tapered (BSPT).

BRITISH STANDARD PIPE PARALLEL (BSPP) :

This connection has a male half with a 300 seat, and a female half with a rotating tapered nose, that forms the seal.

NOTE: The male connector may appear to look like the male American National Pipe Straight Mechanical, or NPSM; however, their thread pitches are not the same, and are not compatible.

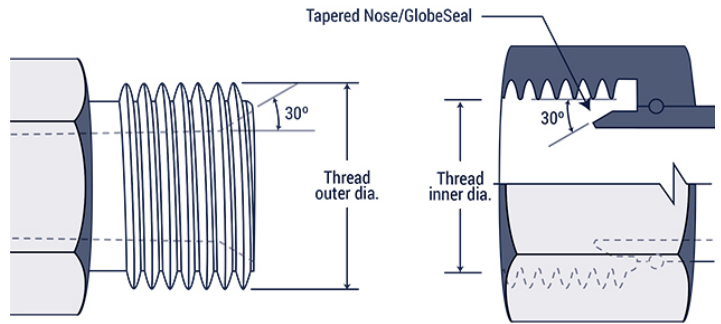

Inch size	Dash size	Thread Size	Male Thread O.D. (in)		Female thread O.D (in)	
1/8	-2	1/8 - 28	3/8	0.38	11/32	0.35
1/4	-4	1/4 - 19	33/64	0.52	15/32	0.47
3/8	-6	3/8 - 19	21/32	0.65	19/32	0.60
1/2	-8	1/2 - 14	13/16	0.82	3/4	0.75
5/8	-10	5/8 - 14	7/8	0.88	13/16	0.80
3/4	-12	3/4 - 14	1 1/32	1.04	31/32	0.97
1	-16	1 - 11	1 5/16	1.30	1 7/32	1.22
1 1/4	-20	1 1/4 - 11	1 21/32	1.65	1 9/16	1.56
1 1/2	-24	1 1/2 - 11	1 7/8	1.88	1 25/32	1.79
2	-32	2 - 11	2 11/32	2.35	2 1/4	2.26

BRITISH STANDARD PIPE TAPERED (BSPT) :

These are connectors where the seal is made between a tapered male and female thread.

NOTE: Although the BSPT male connector appears to look like the National Pipe Tapered Fuel, or NPTF; their thread size and form are not the same and therefore they are not compatible.

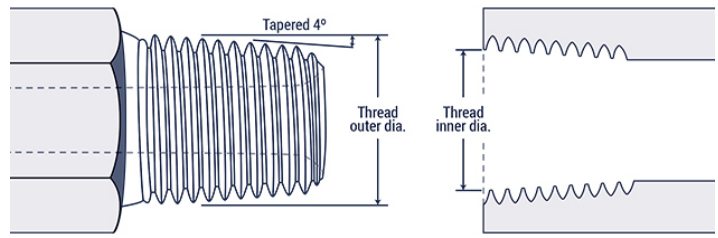

Inch size	Dash size	Thread Size	Male Thread O.D. (in)		Female thread O.D (in)	
1/8	-2	1/8 - 28	3/8	0.38	11/32	0.35
1/4	-4	1/4 - 19	33/64	0.52	15/32	0.47
3/8	-6	3/8 - 19	21/32	0.65	19/32	0.60
1/2	-8	1/2 - 14	13/16	0.82	3/4	0.75
5/8	-10	5/8 - 14	7/8	0.88	13/16	0.80
3/4	-12	3/4 - 14	1 1/32	1.04	31/32	0.97
1	-16	1 - 11	1 5/16	1.30	1 7/32	1.22
1 1/4	-20	1 1/4 - 11	1 21/32	1.65	1 9/16	1.56
1 1/2	-24	1 1/2 - 11	1 7/8	1.88	1 25/32	1.79
2	-32	2 - 11	2 11/32	2.35	2 1/4	2.26

FLAT FACE PORT WITH BRITISH STANDARD PIPE PARALLEL THREADS (ISO 1179-1) :

DIN 3852, PART 2

These connectors form their seal between the male half and the smooth surface of the female half, using a combination of rings or washers between their parallel threads.

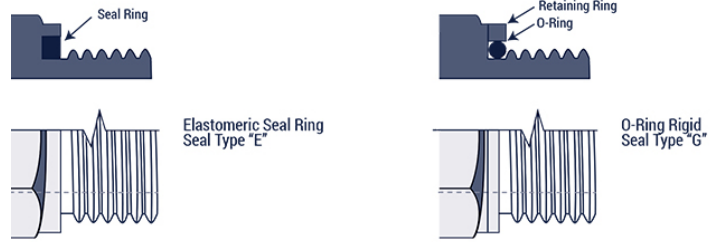

FLAT FACE PORT WITH METRIC THREADS (ISO 9974-1) :

DIN 3852, PART 1

These connectors form their seal between the male half and the smooth surface of the female half, using a combination of rings or washers between their parallel threads.

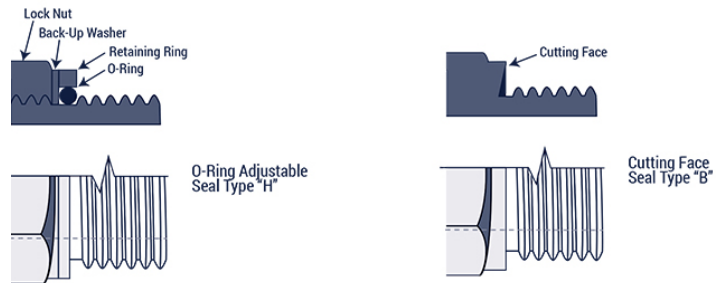

ISO 261 Metric threads

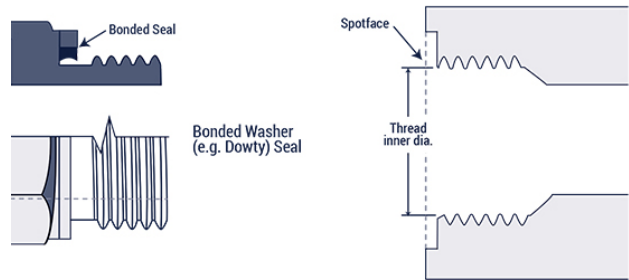

Metric Thread Size	Male Thread O.D. (mm)	Female Thread I.D (mm)
M8 x 1.0	8	7
M10 x 1.0	10	9
M12 x 1.5	12	10.5
M14 x 1.5	14	12.5
M16 x 1.5	16	14.5
M18 x 1.5	18	16.5
M20 x 1.5	20	18.5
M22 x 1.5	22	20.5
M24 x 1.5	24	22.5
M26 x 1.5	26	24.5
M27 x 2.0	27	25
M33 x 2.0	33	31
M36 x 2.0	36	34
M42 x 2.0	42	40
M45 x 2.0	45	43
M48 x 2.0	48	46

ISO 6149 METRIC POST AND STUD ENDS:

ISO 261 THREADS & O-RING SEAL

Connection with both male and female halves having straight threads. The female half has a smooth surface and a chamfer, and the male half has an O-ring. That O-ring compresses against the female chamfer to form the seal. The male and female threads mesh to form a solid connection.

NOTE: Except for the metric threads on the ISO 6149, it connects in the same way as the SAE J1926-10-ring Boss.

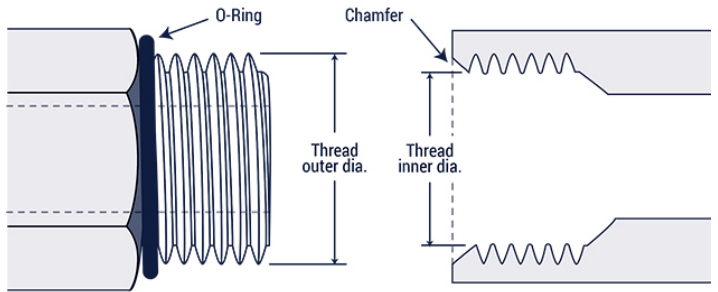

Metric Thread Size	Male Thread O.D. (mm)	Female Thread I.D (mm)
M8 x 1.0	8	7
M10 x 1.0	10	9
M12 x 1.5	12	10.5
M14 x 1.5	14	12.5
M16 x 1.5	16	14.5
M18 x 1.5	18	16.5
M22 x 1.5	22	20.5
M27 x 2.0	27	25
M33 x 2.0	33	31
M42 x 2.0	42	40
M48 x 2.0	48	46
M60 x 2.0	60	58

METRIC 60° CONE :

DIN 7631

These connectors commonly found in hydraulic systems. The female connector has a globeseal seat, while the male has a 60° recessed cone (which forms the seal against the female's tapered nose). Both male and female have straight threads, that mesh to form a solid connection.

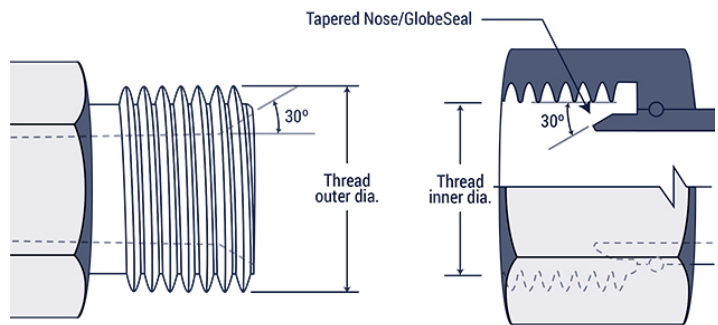

Pipe/Tube O.D. (mm)	Metric Thread Size	Male Thread O.D. (mm)	Female Thread I.D (mm)
6	M12 x 1.5	12	10.5
8	M14 x 1.5	14	12.5
10	M16 x 1.5	16	14.5
12	M18 x 1.5	18	16.5

15	M22 x 1.5	22	20.5
18	M26 x 1.5	26	24.5
22	M30 x 1.5	30	28.5
28	M38 x 1.5	38	36.5
35	M45 x 1.5	45	43.5
52	M52 x 1.5	52	50.5

METRIC COMPRESSION FITTINGS (DIN 2353 24° CONE) :

Both male and female connectors have straight threads, with the male having a 24° cone, and the three female connectors a sealing surface. The 24° cone (male) and the sealing surfaces (females) form the seal.

There are two types of connectors - the DIN 2353 L light class, and the DIN 2353 S heavy class. The chart below lists tube sizes and thread dimensions for each class:

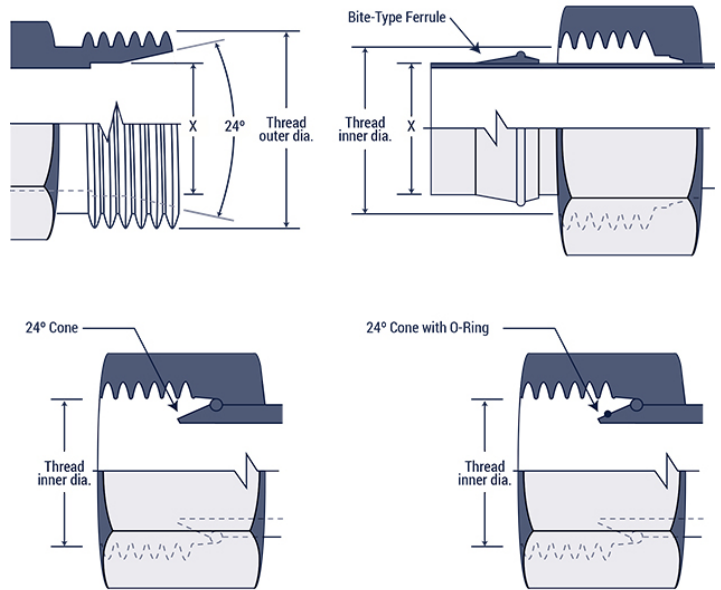

DIN 2353 L Tube O.D.(mm)	DIN 2353 S Tube O.D. (mm)	Metric Thread Size	Male Thread O.D. (mm)	Female Thread I.D (mm)
6		M12 x 1.5	12	10.5
8	6	M14 x 1.5	14	12.5
10	8	M16 x 1.5	16	14.5
12	10	M18 x 1.5	18	16.5
	12	M20 x 1.5	20	18.5
15	14	M22 x 1.5	22	20.5
	16	M24 x 1.5	24	22.5
18		M26 x 1.5	26	24.5
22	20	M30 x 2.0	30	28
28	25	M36 x 2.0	36	34
	30	M42 x 2.0	42	40
35		M45 x 2.0	45	43
42	38	M52 x 2.0	52	50

JAPANESE INDUSTRIAL STANDARD JIS 300 FLARE :

Both male and female connectors have straight threads, however the female has a 300 seat, and the male a 30° seat. (Although the 30° seat and BSPP-like thread dimensions differ from the American 37° Flare, the connections are very much alike.)

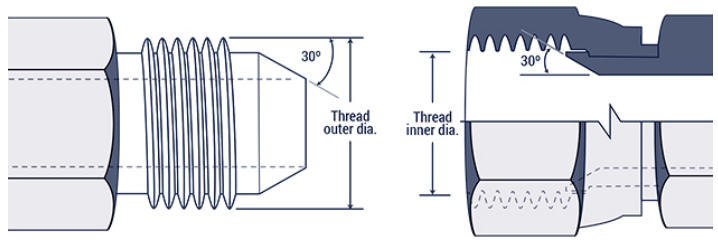

Inch size	Dash size	Thread Size	Male Thread O.D. (in)		Female thread O.D (in)	
1/8	-2	1/8 - 28	3/8	0.38	11/32	0.35
1/4	-4	1/4 - 19	33/64	0.52	15/32	0.47
3/8	-6	3/8 - 19	21/32	0.65	19/32	0.60
1/2	-8	1/2 - 14	13/16	0.82	3/4	0.75
5/8	-10	5/8 - 14	7/8	0.88	13/16	0.80
3/4	-12	3/4 - 14	1 1/32	1.04	31/32	0.97
1	-16	1 - 11	1 5/16	1.30	1 7/32	1.22
1 1/4	-20	1 1/4 - 11	1 21/32	1.65	1 9/16	1.56
1 1/2	-24	1 1/2 - 11	1 7/8	1.88	1 25/32	1.79
2	-32	2 - 11	2 11/32	2.35	2 1/4	2.26

KOMATSU 30° FLARE (JIS METRIC) :

These connectors are commonly used on Komatsu equipment. With a 30° seat and parallel metric threads, it's not unlike the JIS 300 flare (the difference being the metric threads vs. the BSPP-like thread dimensions on the JIS 300).

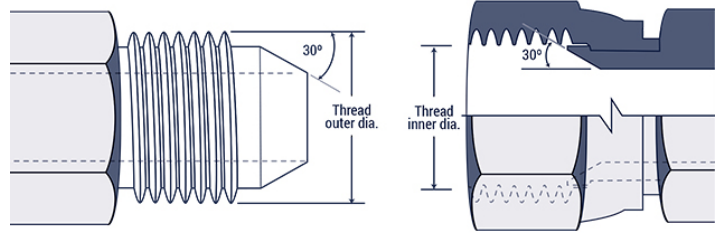

Dash Size	Metric Thread Size	Male Thread O.D. (mm)	Female Thread I.D (mm)
-6	M18 x 1.5	18	16.5
-8	M22 x 1.5	22	20.5
-10	M24 x 1.5	24	22.5
-12	M30 x 1.5	30	28.5
-16	M33 x 1.5	33	31.5
-20	M36 x 1.5	36	34.5
-24	M42 x 1.5	42	40.5

Inch size	Dash size	Threads per Inch	Male Thread O.D. (in)	Female thread O.D (in)
1/8	-2	27	13/32	3/8
1/4	-4	18	17/32	1/2
3/8	-6	14	11/16	5/8
1/2	-8	14	27/32	25/32
3/4	-12	14	1 1/16	1
1	-16	11 1/2	1 5/16	1 1/4
1 1/4	-20	11 1/2	1 21/32	1 19/32
1 1/2	-24	11 1/2	1 29/32	1 13/16
2	-32	11 1/2	2 3/8	2 5/16